











Assembly Instruction for 1025-906

Part List

Parts#	Description	Pattern	Q'ty	Parts#	Description	Pattern	Q'ty
A	Bolt 2.95" L		8 pieces	F	Front Leg		2 pieces
B	Flat Washer		9 pieces	G	Back Frame with Leg		1 Bag
C	Lock Washer		9 pieces	H	Bolt 1.96" L		1 piece
D	Allen Wrench		1 piece	I	Cover		1 Bag
E	Seat Frame		1 Bag	J	Pillow		1 piece

STEP 1.

The parts are in the bag located at the rear of the seat cushion. Open and remove carefully so damage does not occur. Attach seat Frame(E) to back frame using bolt(A and H), lock washer(C), flat washer(B),with allen wrench(D).

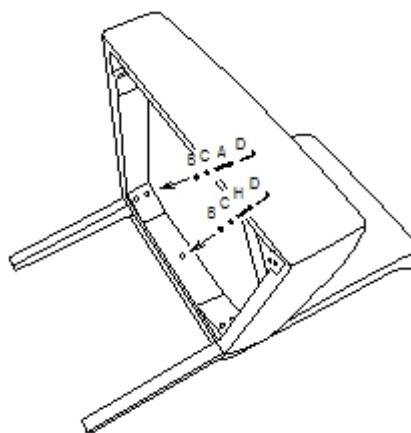

STEP 2. Attach front leg(F) to seat frame using bolt(A), lock washer(C), flat washer(B),with allen wrench(D),.Now tighten all bolts securely. Caution do not over thighten bolts as damage could occur.

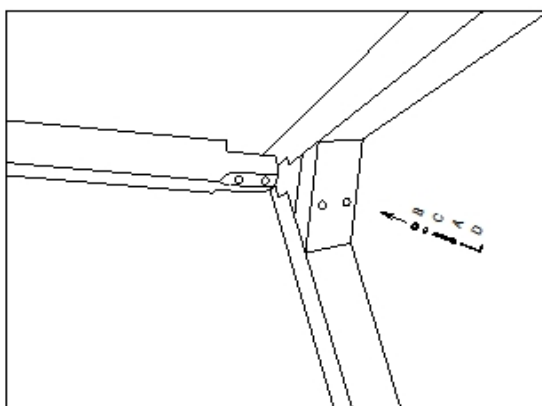
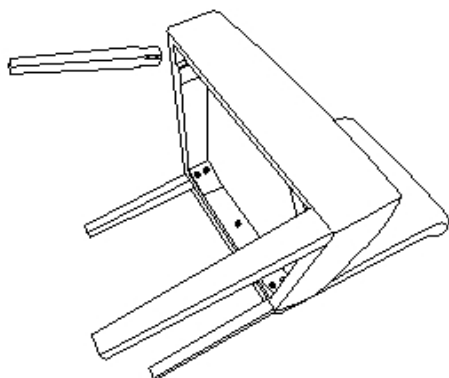

STEP 3.

Insert the Cover (I) to the frame as picture shows starting at the top and working down until complete.

