

- 1** Turn the under side of the Table Top over and place it on a clean and smooth surface such as rug or carpet to avoid the Table Top from being scratched.

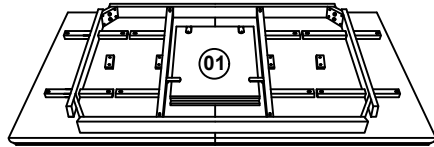

- 4** Turn the assembled Table over carefully, pull the Table Top to both two sides then lift up the Center Leaf from the compartment and turn the Center Leaf to open to lie on apron.

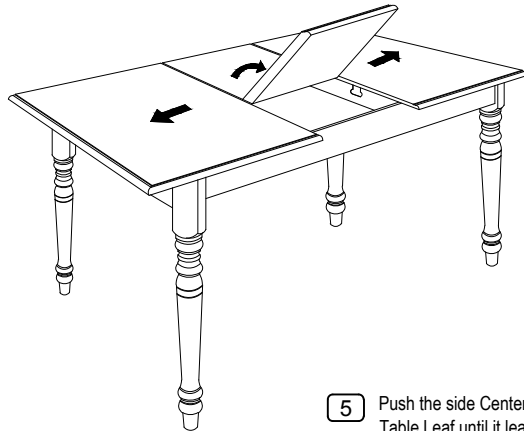

- 2** Fix the turned Leg to the corner of the apron with the Flat Washer, Spring Washer And Hex Nut using the Spanner to tighten it.

Remove the plastic cover from the Pedestal and Footings.

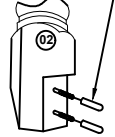

- 3** Repeat the same step for the other three Legs.

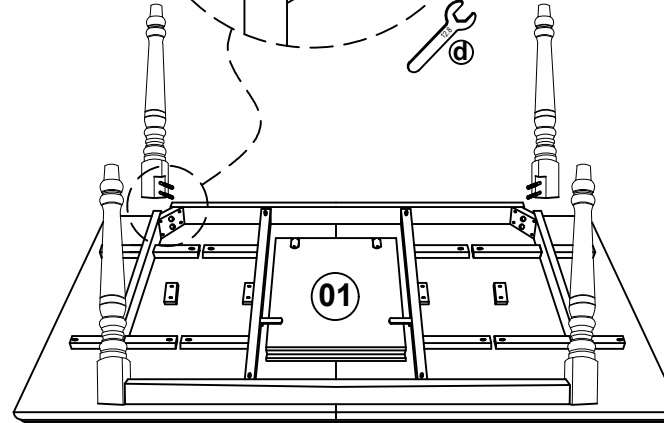
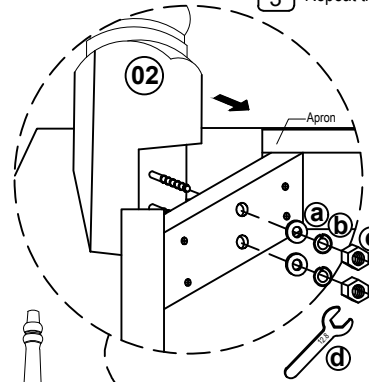

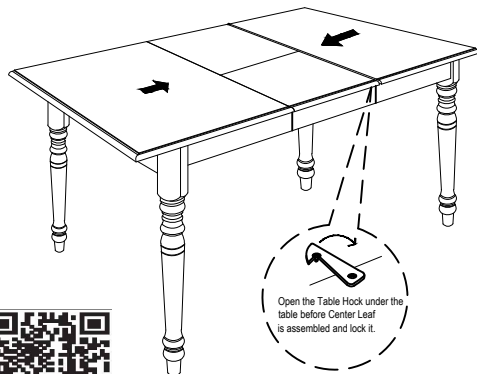

- 5** Push the side Center Top at both end close to the Table Leaf until it leaves no empty spaces.



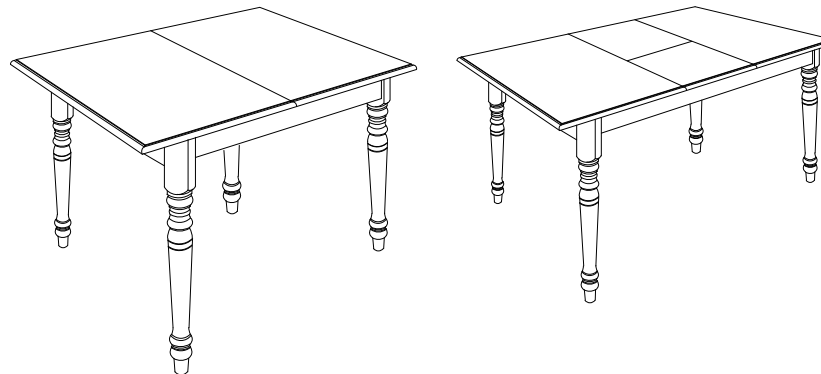



Open the Table Hook under the table before Center Leaf is assembled and lock it.



List of Parts For 1 Set

01		Table Top	1
02		Table Leg With Nail Leg	4

List of Hardware For 1 Set

a		Flat Washer $\frac{5}{16}$ " x 22mm	8
b		Spring Washer $\frac{5}{16}$ "	8
c		Hexagon Nut $\frac{5}{16}$ " x 7mm	8
d		Spanner 12.8mm	1

⚠ IMPORTANT NOTES:

- Keep all hardware and small parts out of reach of children.
- Remove all staples and packing straps before you start to assemble.
- Do not discard main cartons and wrapping material until assembly is complete.
- Check to be sure you have all parts and hardware.
- Place all wooden parts on a clean soft surface to avoid parts from being scratched.
- Do not tighten all screws / bolts until completely assembled.
- Check tightness 3x's/year, with use screws can become loose.
- Do not attempt to repair or modify parts that are broken or defective. Please contact us immediately.
- Enjoy your new furniture!



Step 1

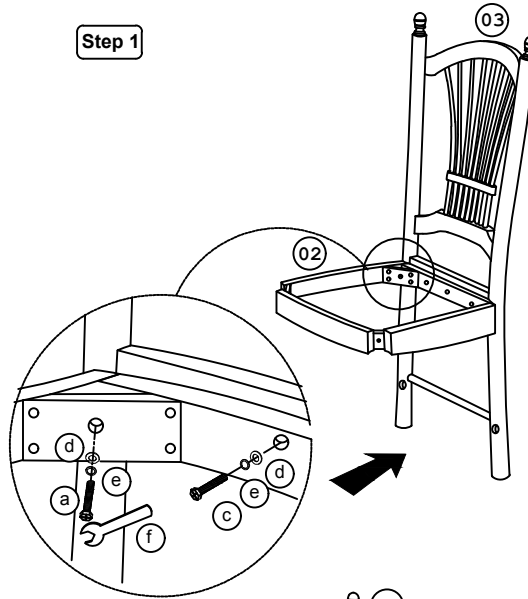

Step 2

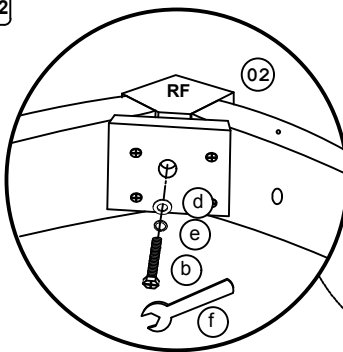

Step 3

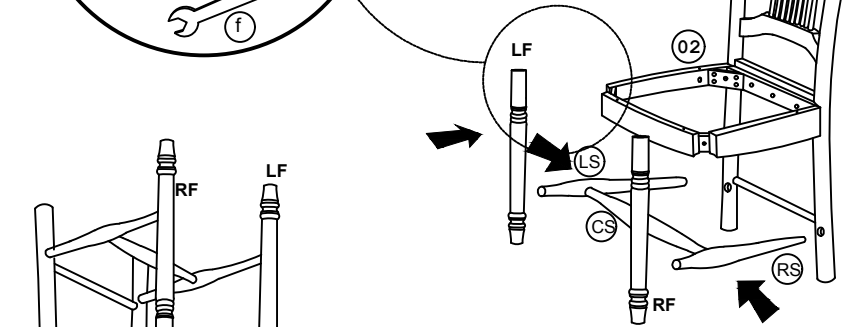

Step 4

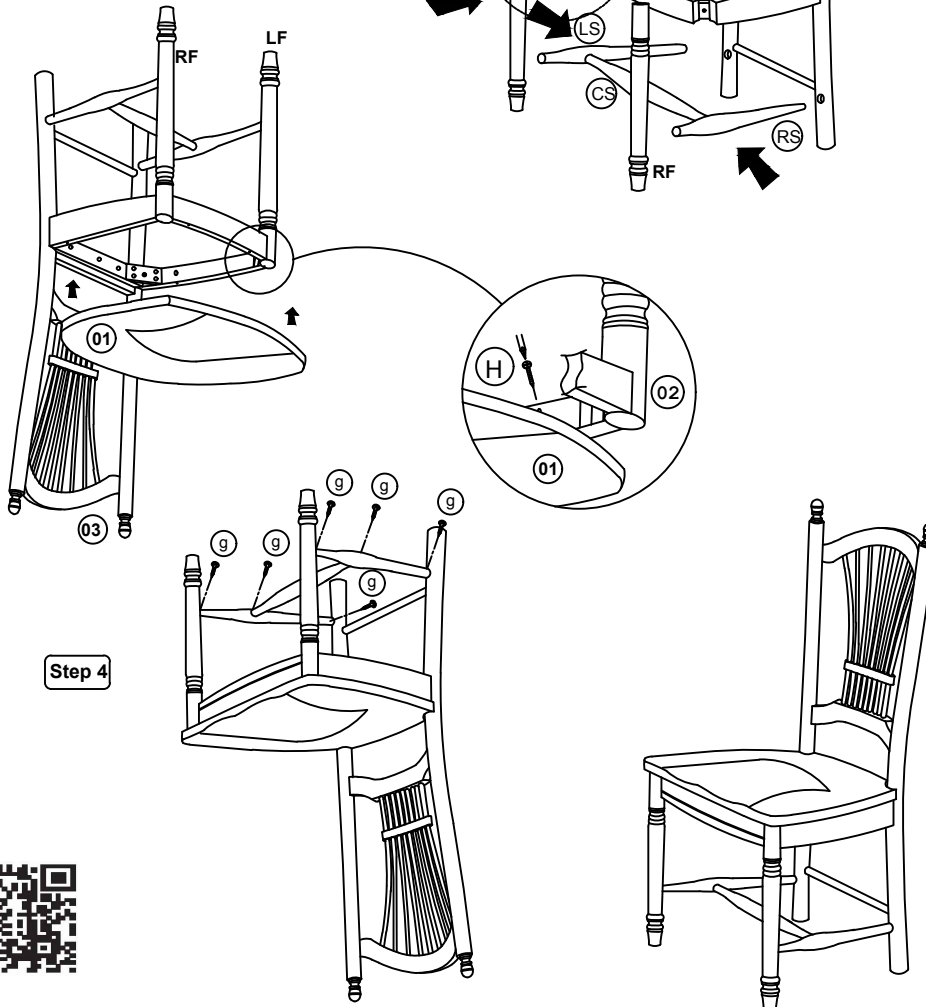

List of Parts For 1 Set

Code	Figure	Part	Qty.
01		Seat Board	1
02		Seat Frame	1
03		Back Frame	1
04		Right Front Leg (RF)	1
05		Left Front Leg (LF)	1
06		Right Stretcher (RS)	1
07		Left Stretcher (LS)	1
08		Center Stretcher (CS)	1

List of Hardware For 1 Set

Code	Figure	Hardware	Qty.
a		Hex. Bolt 80mm	2
b		Hex. Bolt 60mm	2
c		Hex. Bolt 40mm	3
d		Flat Washer	7
e		Spring Washer	7
f		Spanner	1
g		PHRS Screw # 8 x 1 1/4"	6
h		PHRS Screw # 8 x 1"	4

IMPORTANT NOTES:

- Keep all hardware and small parts out of reach of children.
- Remove all staples and packing straps before you start to assemble.
- Do not discard main cartons and wrapping material until assembly is complete.
- Check to be sure you have all parts and hardware.
- Place all wooden parts on a clean soft surface to avoid parts from being scratched
- Do not tighten all screws / bolts until completely assembled.
- Check tightness 3x's/year, with use screws can become loose.
- Do not attempt to repair or modify parts that are broken or defective. Please contact us immediately.
- Enjoy your new furniture!

