



701 E Industrial PK Dr
Manchester NH 03109
877-364-8464
www.sunsettrading.com
info@sunsettrading.com

**Pls Check to make sure you have all parts otherwise contact local retailer or Sunset Trading customer service at 877-364-8464"

Thank You for purchasing this Quality product. It has been engineered for easy assembly yet constructed for durability. Please take the time to read and follow the instruction while assembling.

ASSEMBLY INSTRUCTION

Round Pedestal Butterfly Table

47" x 48"L x 66"L x 30"H

Model : DLU-ADW-TPB-4866 (TCVEB-1119)

Sunset Trading[®]
a div of Sunset Furniture Intl.LLC

Step 1

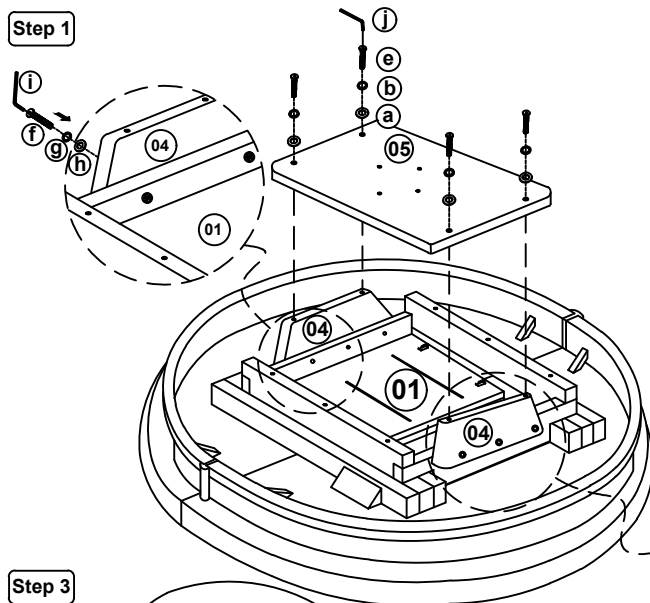

Step 3

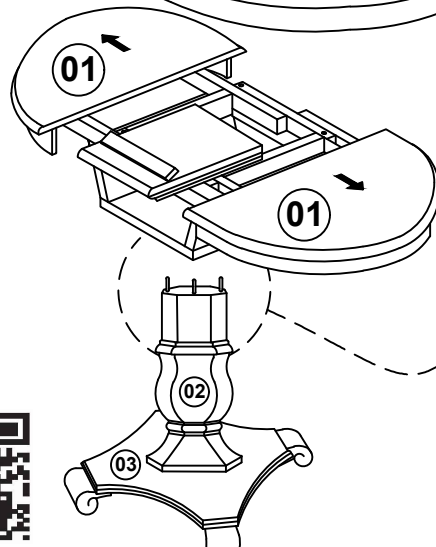

Step 2

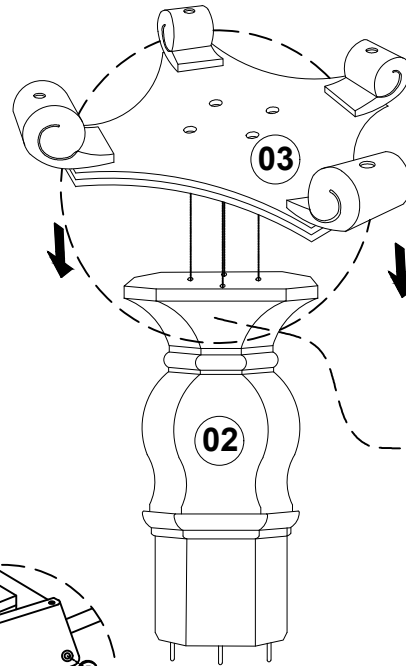

Step 4

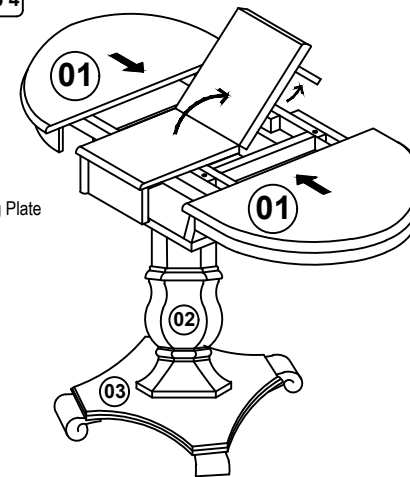

List of Part For 1 Set

01		Table Top	1
02		Pedestal	1
03		Bottom Panel	1
04		Supporting Rail	2
05		Mounting Plate	1

List of hardware For 1 Set

a		Flat Washer 5/16" x 22mm	12
b		Spring Washer 5/16"	12
c		Hexagon Nut 5/16" x 7mm	4
d		Spanner 12.8mm	1
e		JCBC Bolt M8 x 40mm	8
f		JCBC Bolt M6 x 40mm	6
g		Spring Washer 1/4"	6
h		Flat Washer 1/4" x 13mm	6
i		Allen Key M4	1
j		Allen Key M5	1

Important Notes

- * Keep all hardware parts out of reach of children.
- * Must tighten screws periodically. With use screws will become loose. Check tightness of all screws every 6-8 weeks.
- * Don't attempt to repair or modify parts that are broken or defective. Please contact the store immediately.
- * Do not tighten all screw / bolt until all completely assembled



MADE IN MALAYSIA Assembly Completed !!.





Thank You for purchasing this Quality product. It has been engineered for easy assembly yet constructed for durability. Please take the time to read and follow the instruction while assembling.

ASSEMBLY INSTRUCTION

SIDE CHAIR

19 1/2"(W) x 21" (D) x 38"(H)

Model : DLU-ADW-C12
(C-1118-RTA)

Sunset Trading[®]
a div of Sunset Furniture Intl.LLC

701 E Industrial PK Dr
Manchester NH 03109
877-364-8464

www.sunsettrading.com
info@sunsettrading.com

**Pls Check to make sure you have all parts otherwise contact local retailer or Sunset Trading customer service at 877-364-8464"

Step 1

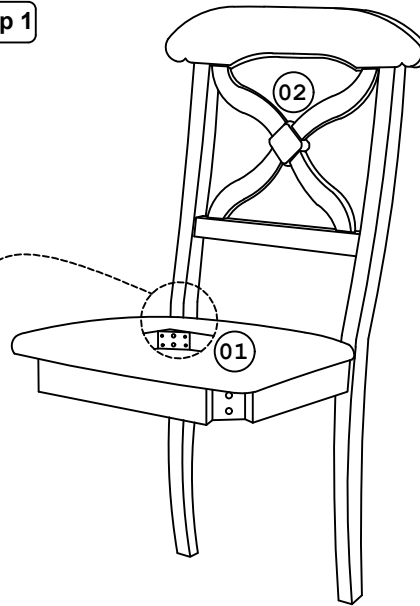

List of Part For 1 Set

Code	Figure	Part	Qty.
01		Seat Frame	1
02		Chair Back	1
03		Front Leg (R)	1
04		Front Leg (L)	1

List of hardware For 1 Set

Code	Figure	Hardware	Qty.
a		Hex. Bolt M6 x 80mm	4
b		Hex. Bolt M6 x 60mm	4
c		Hex. Bolt M6 x 40mm	2
d		Flat Washer 1/4" x 18mm	10
e		Spring Washer 1/4"	10
f		Spanner 10mm	1

Step 2

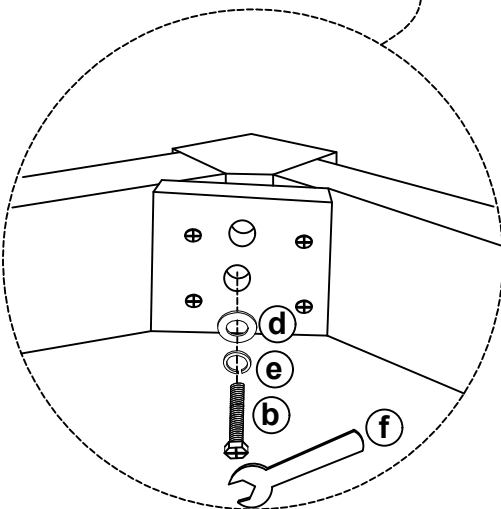
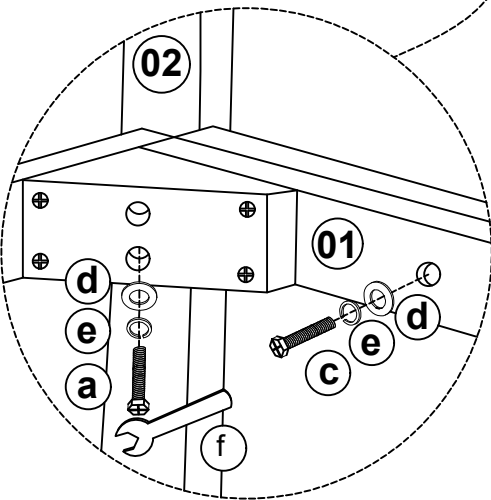
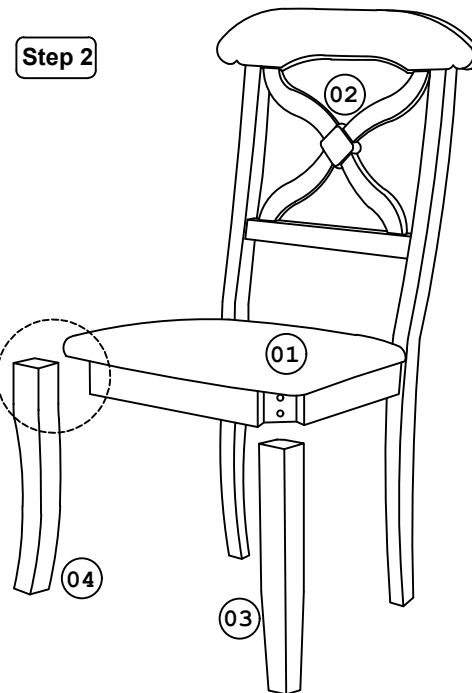

Important Notes

- * Keep all hardware parts out of reach of children.
- * Must tighten screws periodically. With use screws will become loose. Check tightness of all screws every 6-8 weeks.
- * Don't attempt to repair or modify parts that are broken or defective. Please contact the store immediately.
- * Do not tighten all screw / bolt until all completely assembled.

Notes

- * Place all wooden parts on a clean and smooth surface such as a rug or carpet to avoid the parts from being scratched.
- * Check to be sure that you have all parts and hardware.
- * Remove all wrapping materials including staples & packing straps before you start to assemble.
- * Do not tighten all screws / bolts until all completely assembled.

Care And Maintenance

- * The Touch of a soft cloth is all the maintenance your wood pieces will ever need.
- * Never use harsh chemicals or abrasive cleaner as they could mark or destroy finish.





701 E Industrial PK Dr
 Manchester NH 03109
 877-364-8464
 www.sunsettrading.com
 info@sunsettrading.com

**Pls Check to make sure you have all parts otherwise contact local retailer or Sunset Trading customer service at 877-364-8464"

Thank You for purchasing this Quality product. It has been engineered for easy assembly yet constructed for durability. Please take the time to read and follow the instruction while assembling.

ASSEMBLY INSTRUCTION

SERVER

48"L x 17"D x 36 1/2"H

Model : DLU-ADW-SER (S-1118)

Sunset Trading[®]
 a div of Sunset Furniture Intl.LLC

Step 1

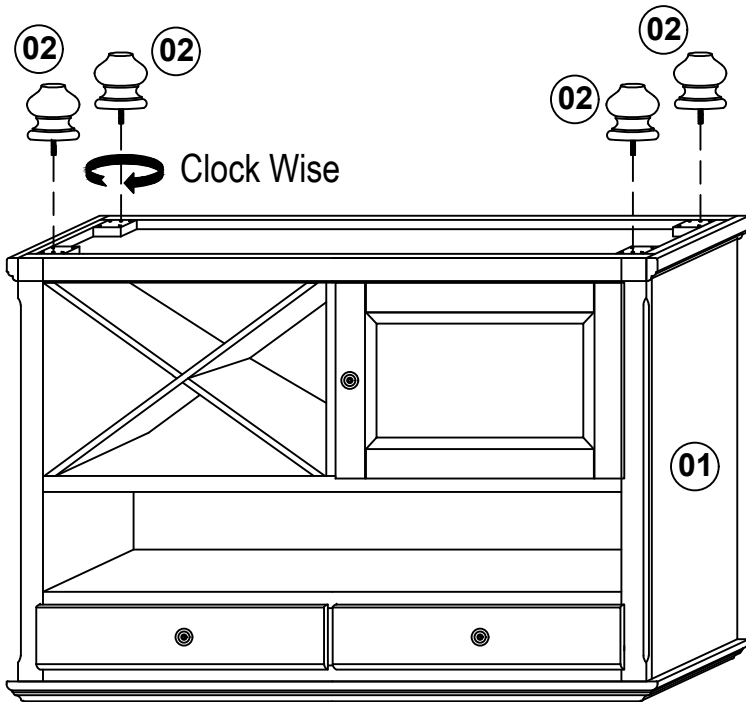

Remove the plastic cover from the Pedestal and Bun Leg.

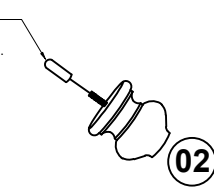

Step 2

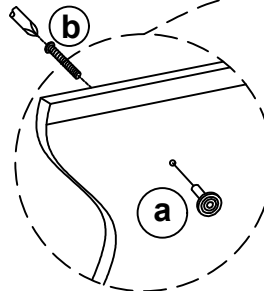
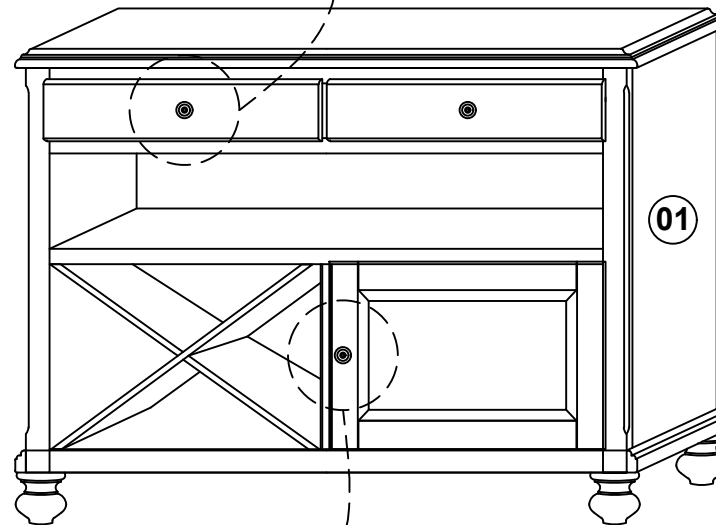

List of Part For 1 Set

01		CABINET	1
02		BUN LEG	4

List of hardware For 1 Set

a		HANDLE	3
b		THMS SCREW 5/32" x 25mm	3

Important Notes

- * Keep all hardware parts out of reach of children.
- * Must tighten screws periodically. With use screws will become loose. Check tightness of all screws every 6-8 weeks.
- * Don't attempt to repair or modify parts that are broken or defective. Please contact the store immediately.
- * Do not tighten all screw / bolt until all completely assembled

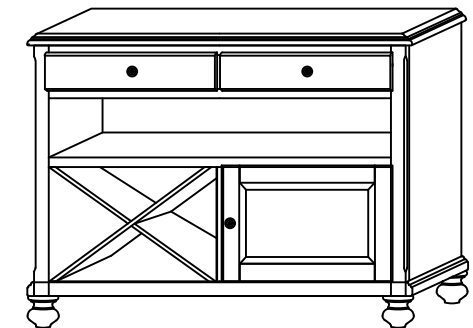

MADE IN MALAYSIA Assembly Completed !!..