



Thank You for purchasing this Quality product. It has been engineered for easy assembly yet constructed for durability. Please take the time to read and follow the instruction while assembling.

# ASSEMBLY INSTRUCTION

38" ARROW BACK WINDSOR CHAIR

18"(W) x 20" (D) x 38 1/2"(H)

Model : DLU-820-RTA (C-0623-RTA)

**Sunset Trading®**

a div of Sunset Furniture Intl.LLC

701 E Industrial PK Dr

Manchester NH 03109

877-364-8464

www.sunsettrading.com

info@sunsettrading.com

\*\*Pls Check to make sure you have all parts otherwise contact local retailer or Sunset Trading customer service at 877-364-8464"

## Step 1

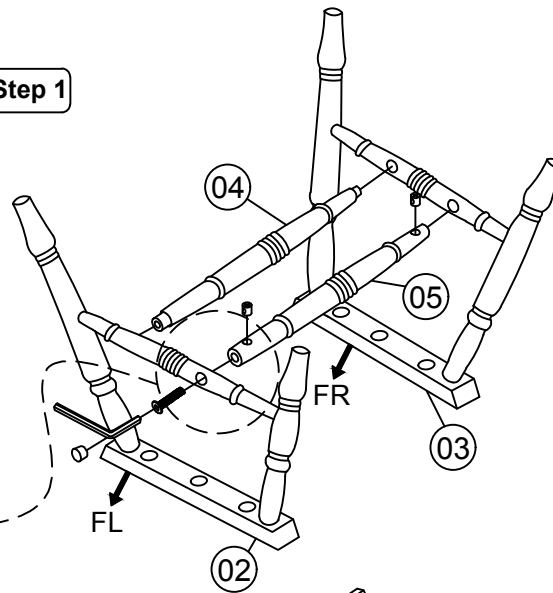

### List of Part For 1 Chair

01		Chair Back	1
02		Base Plate R	1
03		Base Plate L	1
04		Front Stretcher	1
05		Back Stretcher	1

### List of hardware For 1 Chair

a		JCBC Bolt M6 x 45mm	2
b		JCBC Bolt M6 x 30mm	6
c		Spring Washer 1/4"	6
d		Flat Washer 1/4" x 13mm	6
e		JRN Nut	2
f		Allen Key M4	1
g		Wood Button	2

## Step 2

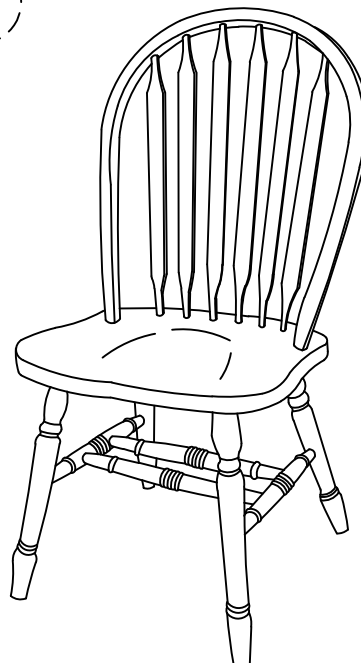
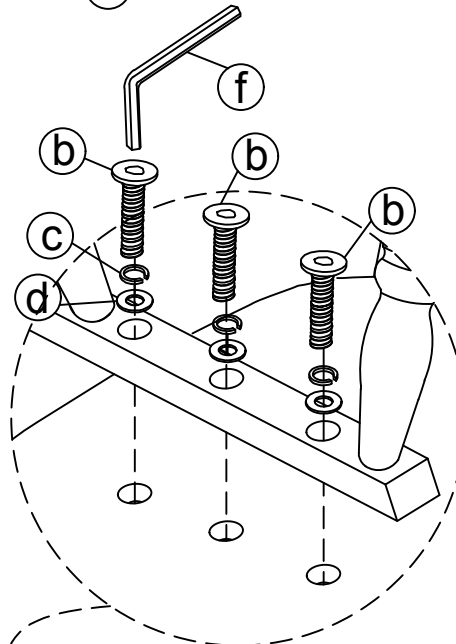
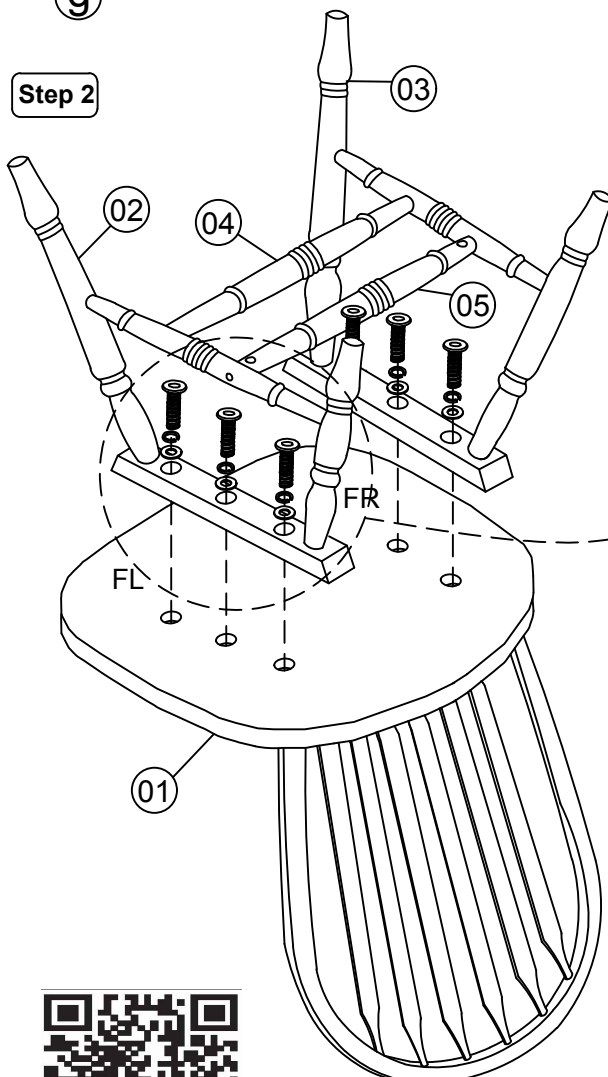

### Important Notes

- \* Keep all hardware parts out of reach of children.
- \* Must tighten screws periodically. With use screws will become loose. Check tightness of all screws every 6-8 weeks.
- \* Don't attempt to repair or modify parts that are broken or defective. Please contact the store immediately.
- \* Do not tighten all screw / bolt until all completely assembled.

### Notes

- \* Place all wooden parts on a clean and smooth surface such as a rug or carpet to avoid the parts from being scratched.
- \* Check to be sure that you have all parts and hardware.
- \* Remove all wrapping materials including staples & packing straps before you start to assemble.
- \* Do not tighten all screws / bolts until all completely assembled.

### Care And Maintenance

- \* The Touch of a soft cloth is all the maintenance your wood pieces will ever need.
- \* Never use harsh chemicals or abrasive cleaner as they could mark or destroy finish.

